

10GBASE-SR X2 Transceiver, 850nm, SC Connectors, 300m over Multi-Mode Fiber.

Description

These 10 GBd X2 optical transceivers are designed for Storage, IP network and LAN. They are hot pluggable modules in the Z-direction that are mainly usable in typical router/switch line card applications. They are fully integrated 10.3 Gb/s optical transceiver modules that consist of an 850nm wavelength VCSEL optical transmitter and receiver, XAUI interface, Mux and Demux with clock and data recovery (CDR). In addition, they comply with the X2 Multi Sourcing Agreement (MSA).



Features

- Up to 10 GBd bi-directional data links.
- Compliant with IEEE 802.3ae, 10GBASE-SR application.
- Compliant with X2 MSA.
- 850nm VCSEL laser.
- PIN Photo-detector.
- XAUI electrical interface: 4 lanes @ 3.125 GBd.
- MDIO, DOM (Digital Optics Monitoring) support.
- Hot Z-Pluggable.
- SC Connectors
- Up to 300m on MMF
- Power Supply: 5V/3.3V/Adaptable Power Supply (APS: 1.2V)
- RoHS Compliance
- Operating temperature range: 0°C to 70°C.

Applications

- 10 GBd Ethernet.

Technical Standard:

Absolute Maximum Ratings

Parameter	Symbol	Min	Typ	Max	Unit	Remarks
Storage Ambient Temperature	T_S	- 40		85	°C	
Supply Voltage (3.3V)	V_3	0		4	V	
Supply Voltage (APS)	V_{APS}	0		1.5	V	
Optical Receiver Input	P_{IMAX}			1.5	dBm	Average

General Specifications

Parameter	Symbol	Min	Typ	Max	Unit	Remarks
Data Rate	DR		10.3125		GBd	
Bit Error Rate	BER			10^{-12}		
Total Power Consumption	P			3	W	
Supply Voltage (+3.3V)	V_{CC3}	3.14	3.3	3.47	V	Operating Environment
Supply Voltage (APS)	V_{CCAPS}	1.152	1.2	1.248	V	Operating Environment
Supply Current (+3.3V)	I_{CC3}			300	mA	
Supply Current (APS)	I_{CCAPS}			1000	mA	
Case Operating Temperature	T_C	0		70	°C	

Link Distances

Parameter	Fiber Type	Modal Bandwidth @ 850nm (MHz-km)	Distance Range (Km)
10.3 GBd	62.5/125um MMF	160	2-26
	62.5/125um MMF	200	2-33
	50/125um MMF	400	2-66
	50/125um MMF	500	2-82
	50/125um MMF	2000	2-300

Optical Characteristics - Transmitter

V_{CC3} = 3.14V to 3.47V, V_{CCAPS} = 1.152V to 1.248V, T_C = 0°C to 70°C

Parameter	Symbol	Min	Typ	Max	Unit	Remarks
Optical Wavelength	λ	840	850	860	nm	
Launch Power	P_{OUT}	- 7.3		-1.3	dBm	Average
Launch Power in OMA	P_{OUT_OMA}	- 4.3		-2.8	dBm	
Launch Power of OFF Transmitter	P_{OUT_OFF}			-30	dBm	Average
Side Mode Suppression Ratio	SMSR	30			dB	
Spectral Width (RMS)	$\Delta\lambda$			0.45	nm	
Optical Extinction Ratio	ER	3			dB	
Optical Modulation amplitude	OMA	525			uW	
Optical Return Loss Tolerance	ORL_T			12	dB	
Relative Intensity Noise	RIN			- 128	dB/Hz	
Transmitter Dispersion Penalty	TDP			3.9	dB	
Eye Mask Definition	According to IEEE 802.3ae and 10GBASE-SR					

Optical Characteristics - Receiver

V_{CC3} =3.14V to 3.47V, V_{CCAPS} =1.152V to 1.248V, T_C =0°C to 70°C

Parameter	Symbol	Min	Typ	Max	Unit	Remarks
Center Wavelength Range	λ_C	840		860	nm	
Optical Input Power	P_{IN}	-9.9		-1	dBm	Average, Informative
Receiver Sensitivity in OMA	P_{IN_OMA}			-11.1	dBm	Informative
Stressed Receiver Sensitivity	P_{IN_S}			-7.5	dBm	
Receive Reflectance	TR_{RX}			-12	dB	
Receiver electrical 3dB upper cutoff frequency	FR			12.3	GHz	

Electrical Characteristics - DC

V_{CC3} =3.14V to 3.47V, V_{CCAPS} =1.152V to 1.248V, T_C =0°C to 70°C

Parameter	Symbol	Min	Typ	Max	Unit	Remarks
-----------	--------	-----	-----	-----	------	---------

A.

1.2V COMS I/O DC Characteristics (PRTAD; LASI; RESET; TX_ON/OFF)

Open Drain	R_{PU}	10		22	k Ω	
Output High Voltage	V_{OH}	1			V	
Output Low Voltage	V_{OL}			0.15	V	
Input High Voltage	V_{IH}	0.84		1.2	V	
Input Low Voltage	V_{IL}			0.36	V	
Input Pull-Down Current	I_{PD}	20		120	μ A	$V_{IN}=1.2V$

B.

XAUI I/O DC Characteristics (TXLANE[0..3]; RXLANE[0..3])

Differential Input Amplitude (pk – pk)	V_{IN_XAUI}	200		2500	mV	AC Coupled
Differential Output Amplitude (pk – pk)	V_{OUT_XAUI}	800		1600	mV	AC Coupled

C.

MDIO I/O DC Characteristics (MDIO; MDC)

Output Low Voltage	V_{OL}			0.2	V	$I_{OL}=100\mu A$
Output Low Current	I_{OL}			4	mA	
Input High Voltage	V_{IH}	0.84		1.2	V	
Input Low Voltage	V_{IL}			0.36	V	
Pull-Up Supply Voltage	V_{PU}	1.152	1.2	1.248	V	
Input Capacitance	C_{IN}			10	pF	
Load Capacitance	C_{LOAD}			470	pF	
External Pull-Up Resistance	R_{PU}	200			Ω	

Electrical Characteristics - AC

V_{CC3} = 3.14V to 3.47V, V_{CCAPS} = 1.152V to 1.248V, T_C = 0°C to 70°C

Parameter	Symbol	Min	Typ	Max	Unit	Remarks
-----------	--------	-----	-----	-----	------	---------

A.

XAUI Input AC Characteristics (TXLANE[0..3])

Baud Rate	BR_{XAUI_IN}		3.125		GBd	
Baud Rate Tolerance	BR_{TOL_XAUI}	- 100		100	ppm	
Differential Input Impedance	Z_{IN_XAUI}		100		Ω	
Differential Return Loss	RL_{IN}	10			dB	100 MHz to 2.5 GHz
Input Differential Skew	T_{IN_SKEW}			75	ps	Crossing Point
Jitter Amplitude Tolerance	J_{XAUI_TOL}			0.65	UI _{pp}	IEEE 802.3ae

B.

XAUI Output AC Characteristics (RXLANE[0..3])

Baud Rate	BR_{XAUI_OUT}		3.125		GBd	
Baud Rate Variation	BR_{XAUI_VAR}	- 100		100	ppm	
XAUI Eye Mask (far-end)	According to IEEE 802.3ae					
Output Differential Skew	T_{OUT_SKEW}			15	ps	
Output Differential Impedance	Z_{OUT_XAUI}		100		Ω	
Differential Output Return Loss	RL_{OUT}	10			dB	100 MHz to 2.5 GHz
Total Jitter	TJ_{XAUI}			0.35	UI	Near-end No pre-equalization 1 UI=320 ps
Deterministic Jitter	DJ_{XAUI}			0.17	UI	

C.

Power-On Reset Characteristics

Power-On Reset and TX_ONOFF Characteristics	According to X2 MSA Issue					
---	---------------------------	--	--	--	--	--

D.

MDIO I/O AC Characteristics (MDIO; MDC)

MDIO Data Hold Time	T_{HOLD}	10			ns	
MDIO Data Setup Time	T_{SU}	10			ns	
Delay from MDC Rising Edge to MDIO Data Change	T_{DELAY}			300	ns	
MDC Clock Rate	f_{MAX}			2.5	MHz	

Digital Diagnostic

Parameter	Symbol	Min	Typ	Max	Unit	Remarks
Temperature Monitor	T_{MON}	-5		+5	°C	
Laser Bias Monitor	I_{MON}	-10		10	%	
TX Power Monitor	P_{TX}	-3		+3	dBm	
RX Power Monitor	P_{RX}	-3		+3	dBm	

Dimensions:

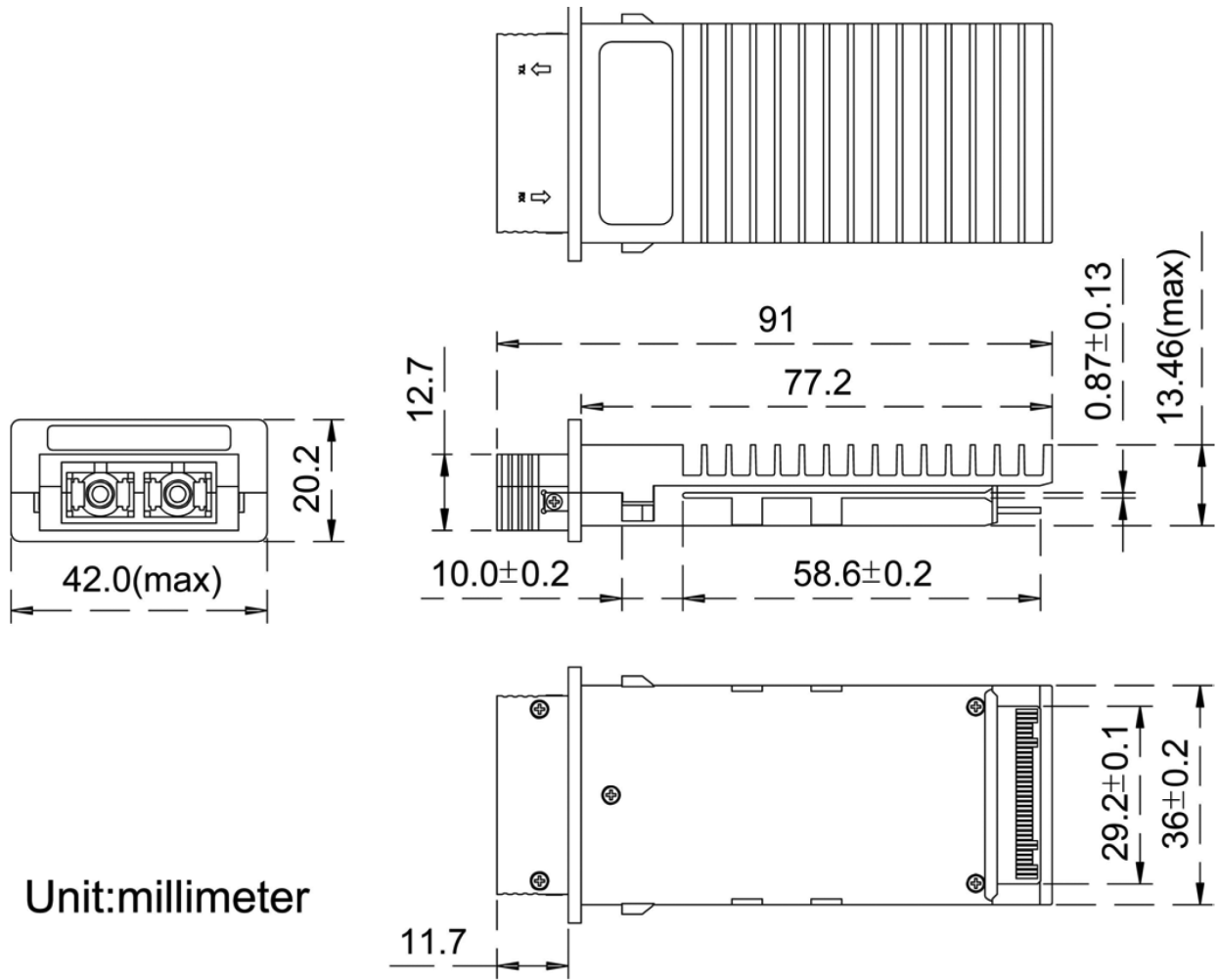

Unit: millimeter

ALL DIMENSIONS ARE $\pm 0.2\text{mm}$ UNLESS OTHERWISE SPECIFIED

Pin Assignment – Pin 1 to Pin 35

PIN #	Symbol	I/O	Logic	Description	PIN #
1	GND	I	Supply	Electrical ground	1
2	GND	I	Supply	Electrical ground	2
3	GND	I	Supply	Electrical ground	3
4	5.0V	I	Supply	Power	4
5	3.3V	I	Supply	Power	5
6	3.3V	I	Supply	Power	6
7	APS	I	Supply	Adaptive Power Supply	7
8	APS	I	Supply	Adaptive Power Supply	8
9	LASI	O	Open Drain	Link Alarm Status Interrupt. 10-22k ohm pull up on host	9
10	RESET	I	1.2V CMOS	TX OFF when MDIO RESET	10
11	VEND SPECIFIC			Vendor Specific Pin. Leave unconnected	11
12	TX ON/OFF	I	1.2V CMOS	Transmitter ON/OFF	12
13	RESERVED			Reserved	13
14	MOD DETECT	O		Pulled low inside module through 1k ohm	14
15	VEND SPECIFIC			Vendor Specific Pin. Leave unconnected	15
16	VEND SPECIFIC			Vendor Specific Pin. Leave unconnected	16
17	MDIO	I/O	Open Drain	Management Data IO	17
18	MDC	I	1.2V CMOS	Management Data Clock	18
19	PRTAD4	I	1.2V CMOS	Port Address bit 4 (Low=0)	19
20	PRTAD3	I	1.2V CMOS	Port Address bit 3 (Low=0)	20
21	PRTAD2	I	1.2V CMOS	Port Address bit 2 (Low=0)	21
22	PRTAD1	I	1.2V CMOS	Port Address bit 1 (Low=0)	22
23	PRTAD0	I	1.2V CMOS	Port Address bit 0 (Low=0)	23
24	VEND SPECIFIC			Vendor Specific Pin. Leave unconnected	24
25	APS SET	O		Feedback output for APS	25
26	RESERVED			Reserved for Avalanche Photodiode use	26
27	APS SENSE	O	Analog	APS Sense Connection	27
28	APS	I	Supply	Adaptive Power Supply	28
29	APS	I	Supply	Adaptive Power Supply	29
30	3.3V	I	Supply	Power	30
31	3.3V	I	Supply	Power	31
32	5.0V		Supply	Power	32
33	GND	I	Supply	Electrical Ground	33
34	GND	I	Supply	Electrical Ground	34
35	GND	I	Supply	Electrical Ground	35

Pin Assignment – Pin 36 to Pin 70

PIN #	Symbol	I/O	Logic	Description	Remarks
36	GND	I	Supply	Electrical ground	
37	GND	I	Supply	Electrical ground	
38	RESERVED			Reserved	
39	RESERVED			Reserved	
40	GND	I	Supply	Electrical ground	
41	RX LANE 0+	O	AC	Module XAUI Output Lane 0+	
42	RX LANE 0-	O	AC	Module XAUI Output Lane 0-	
43	GND	I	Supply	Electrical ground	
44	RX LANE 1+	O	AC	Module XAUI Output Lane 1+	
45	RX LANE 1-	O	AC	Module XAUI Output Lane 1-	
46	GND	I	Supply	Electrical ground	
47	RX LANE 2+	O	AC	Module XAUI Output Lane 2+	
48	RX LANE 2-	O	AC	Module XAUI Output Lane 2-	
49	GND	I	Supply	Electrical ground	
50	RX LANE 3+	O	AC	Module XAUI Output Lane 3+	
51	RX LANE 3-	O	AC	Module XAUI Output Lane 3-	
52	GND	I	Supply	Electrical ground	
53	GND	I	Supply	Electrical ground	
54	GND	I	Supply	Electrical ground	
55	TX LANE 0+	O	AC	Module XAUI Input Lane 0+	
56	TX LANE 0-	O	AC	Module XAUI Input Lane 0-	
57	GND	I	Supply	Electrical ground	
58	TX LANE 1+	O	AC	Module XAUI Input Lane 1+	
59	TX LANE 1-	O	AC	Module XAUI Input Lane 1-	
60	GND	I	Supply	Electrical ground	
61	TX LANE 2+	O	AC	Module XAUI Input Lane 2+	
62	TX LANE 2-	O	AC	Module XAUI Input Lane 2-	
63	GND	I	Supply	Electrical ground	
64	TX LANE 3+	O	AC	Module XAUI Input Lane 3+	
65	TX LANE 3-	O	AC	Module XAUI Input Lane 3-	
66	GND	I	Supply	Electrical ground	
67	RESERVED			Reserved	
68	RESERVED			Reserved	
69	GND	I	Supply	Electrical Ground	
70	GND	I	Supply	Electrical Ground	

Electrical Pad Layout

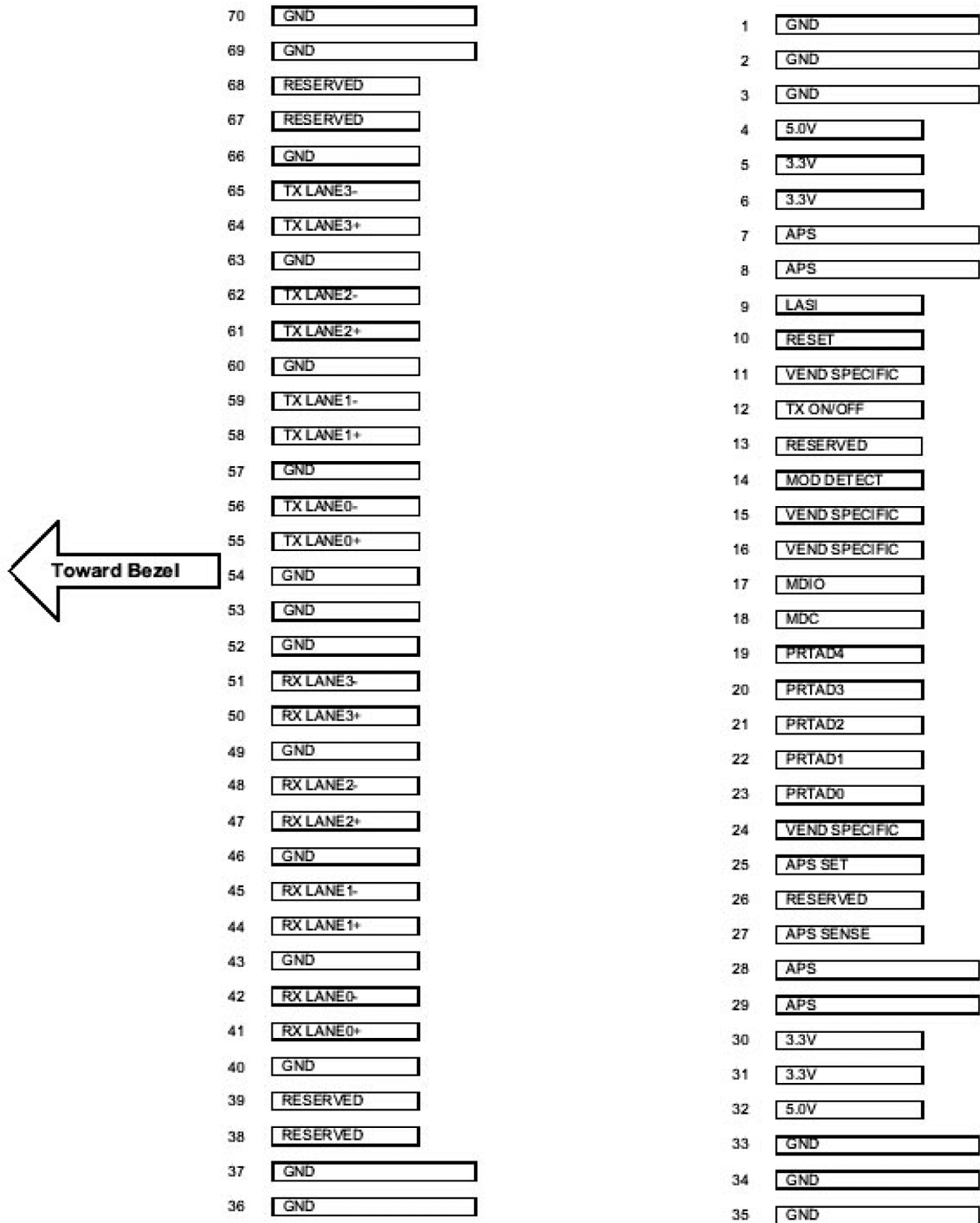

Top of Transceiver PCB

**Bottom of Transceiver PCB
As viewed through top**

Epic Broadband Solutions

751 Maleta Lane Ste 204, Castle Rock, CO 80108

PHONE# 720-904-5200 • FAX# 720-904-5222

www.epicbbs.com